

Semi-Internal "Pop-Action" Pressure Relief Valves for ASME Portable Containers 7583, 8684 and 8685 Series

Application

Designed for use as a primary relief valve on ASME containers such as 250, 500 and 1,000 gallon tanks. Underwriters' Laboratories lists containers systems on which these types of valves are mounted outside the hood without additional protection, if mounted near the hood and fitted with a protective cap.

Features

- Constructed of non-corrosive materials.
- "Pop-action" design keeps product loss at a minimum.
- ASME rated for use with LP-Gas.
- Request RegO Relief Valves on all your original equipment ASME containers for reliable performance.

Materials

Body Brass
 Spring Steel
 Stem Stainless Steel
 Seat Disc Resilient Rubber

Ordering Information

Part Number	Start To Discharge Setting PSIG	A Container Connection M. NPT	B Overall Height (Approx.)	C Height Above Coupling (Approx.)	D Wrench Hex Section	Flow Capacity SCFM/Air		Protective Cap (Included)
						UL (At 120% of Set Pressure)	ASME (At 120% of Set Pressure)	
7583G	250	3/4"	8 3/8"	1 1/8"	1 1/4"	1980	1806	7583-40X
8684G		1"	9 3/8"	1 1/8"	1 1/8"	2620	2565	8684-40
8685G		1 1/4"	11 1/8"	1 1/8"	2 3/8"	4385	4035	7585-40X



7583G

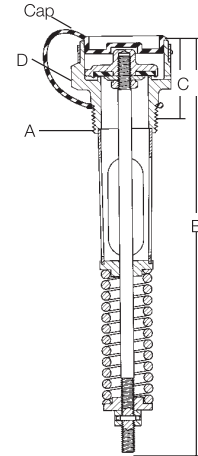

Application

Designed especially for use as a primary relief valve on large stationary storage containers, these low profile relief valves are generally mounted in half couplings. However, they are designed so that the inlet ports clear the bottom of a full 2" coupling. This ensures that the relief valve should always be capable of maximum flow under emergency conditions.

Features

- High capacity, low turbulence design has a maximum guiding area providing for dependable shut-off after opening.
- Built-in spring stop limits the rise of the seat in full open position and prevents the spring from going "solid."
- External 3" NPT threaded body allows easy attachment of vent stacks. Optional pipeaway adapter has break-off groove to prevent damage to the relief valve should piping be stressed by damaging winds.
- "Pop-Action" design keeps product loss at a minimum.
- No guiding projections around the seat disc retainer to bind and hinder opening of valve if body is damaged.



7534

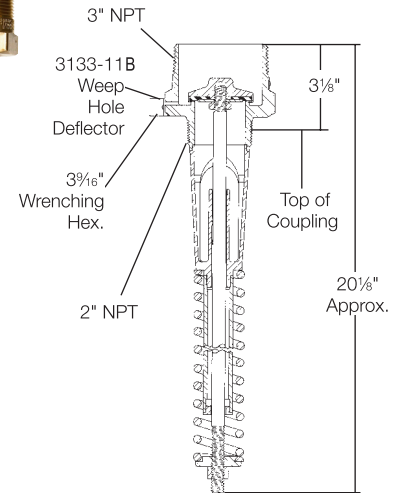

Materials

Body Brass
 Spring Steel
 Stem Stainless Steel
 Seat Disc Resilient Rubber

Ordering Information

Part Number	Start To Discharge Setting PSIG	Container Connection M. NPT	Flow Capacity SCFM/Air*		Accessories	
			UL (At 120% of Set Pressure)	ASME (At 120% of Set Pressure)	Protective Cap	Pipeaway Adapter
7534B	125	2"	6,025	-	7534-40X	7534-20**
7534G***	250		11,675	10,422		

* Flow rates shown are for bare relief valves. Adapters and pipeaways will reduce flow as discussed in the the Foreword section.

** 3" F. NPT outlet connection.

*** Other seat materials are available.